

VIEW W

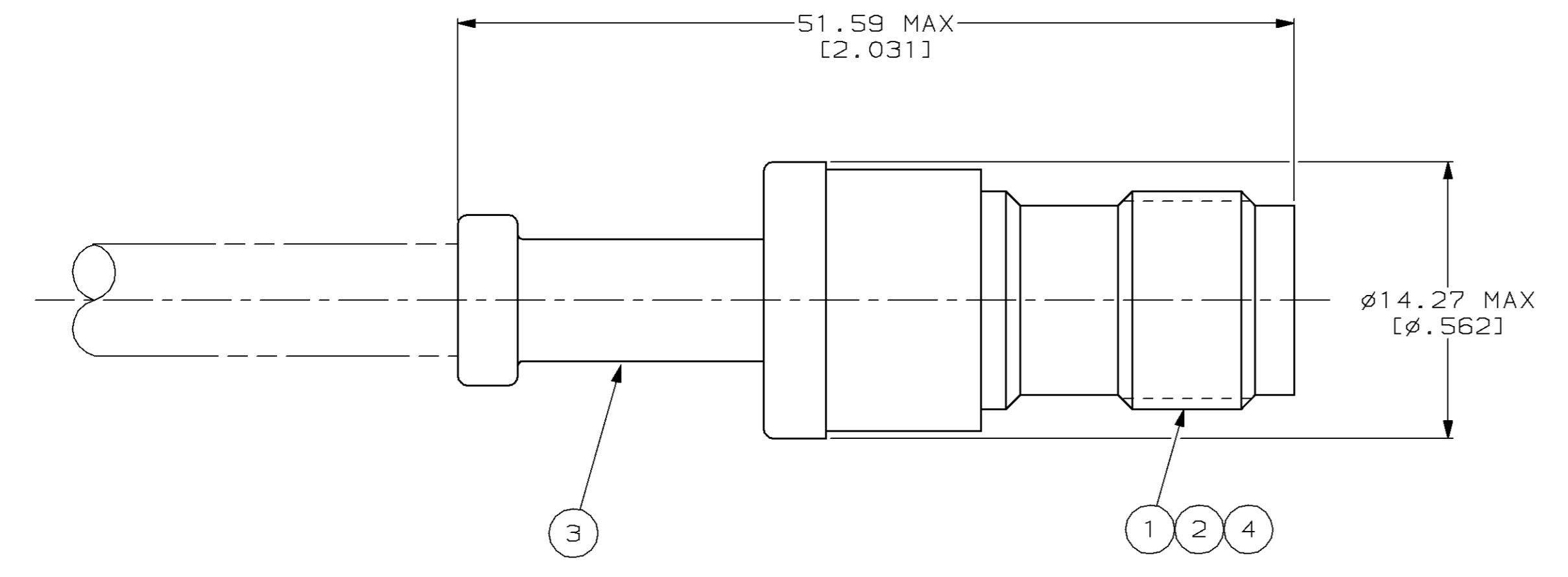

VIEW X

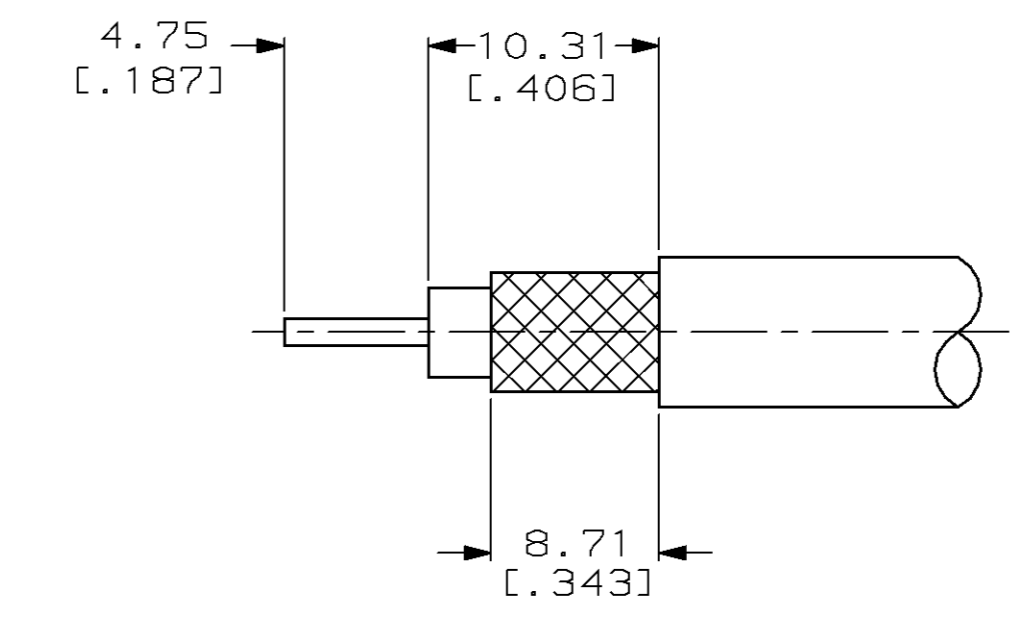

VIEW Y

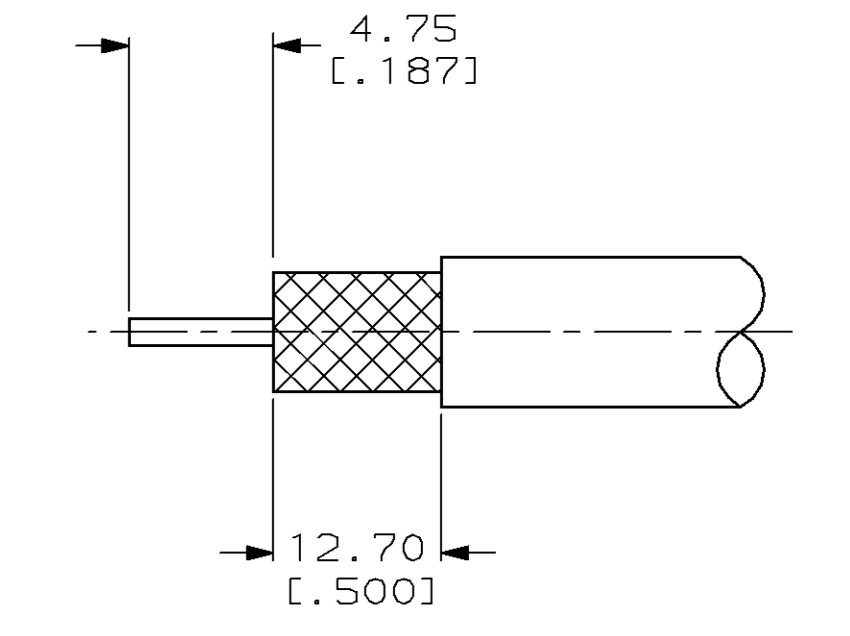

VIEW Z

RECOMMENDED STRIP LENGTH

	RG-142/U, 142A/U & 142B/U	7-225551-6 AMP	220045-2	W & Y	225592-2	225560-1	225471-3	225468-1	7-225551-6
	RG-59B/U & 62B/U	7-225551-3 AMP	220045-3	W & Y	225592-3	225560-3	225471-2	225468-3	7-225551-3
	RG-58A/U, 58C/U & BSX 7002-58C/U	7-225551-2 AMP	220045-2	W & Y	225592-1	225560-2	225471-1	225468-1	7-225551-2
OBSOLETE	RG-225/U	1-225551-2 AMP	220015-1	X & Z	332022	331987	225471-7	225597-2	1-225551-2
	RG-142/U, 142A/U & 142B/U	00779 M39012/27B0006 AMP YY WW	220045-2	W & Y	-	225560-1	1-225471-1	3-225468-1	225551-6
	RG-141/U & 141A/U	00779 M39012/27B0015 AMP YY WW	220045-2	W & Y	225592-1	225560-2	1-225471-1	225468-1	225551-5
	RG-58A/U, 58C/U & BSX 7002-58C/U	²	220045-2	W & Y	-	225560-2	225471-9	2-225468-1	225551-2
	RG-55A/U & 223/U	¹	220045-2	W & Y	225592-2	225560-1	225471-9	225468-1	225551-1
	CABLE SIZE	STAMPING	CRIMP TOOL	VIEW	⁴ GASKET QTY=1	³ FERRULE QTY=1	² CONTACT QTY=1	¹ JACK ASSY QTY=1	PART NUMBER

DO NOT SCALE PRINT. UNLESS SPECIFIED DIMENSIONS IN mm [INCHES] TOLERANCES ON: 2 PLC DEC ± 0.41 [0.016] 3 PLC DEC ± - ANGLES ± -		DR 3-6-91 B. SCOTT	AMP Incorporated Harrisburg, PA 17105-3608
MATERIAL	-	CHK 3-11-91 J. LIPPERT	
FINISH	-	APPD 4-2-91 M. PHILLIPS	NAME JACK, WEATHERPROOF, SERIES, TNC
WEIGHT	-	APPD 4-2-91 J. LIPPERT	PRODUCT SPEC 108-12001
		APPLICATION SPEC	SIZE D 00779
			CAGE CODE 00779
			DRAWING NO 225551
			SCALE 4:1
			SHEET 1 OF 1